

~~February~~ February 1998

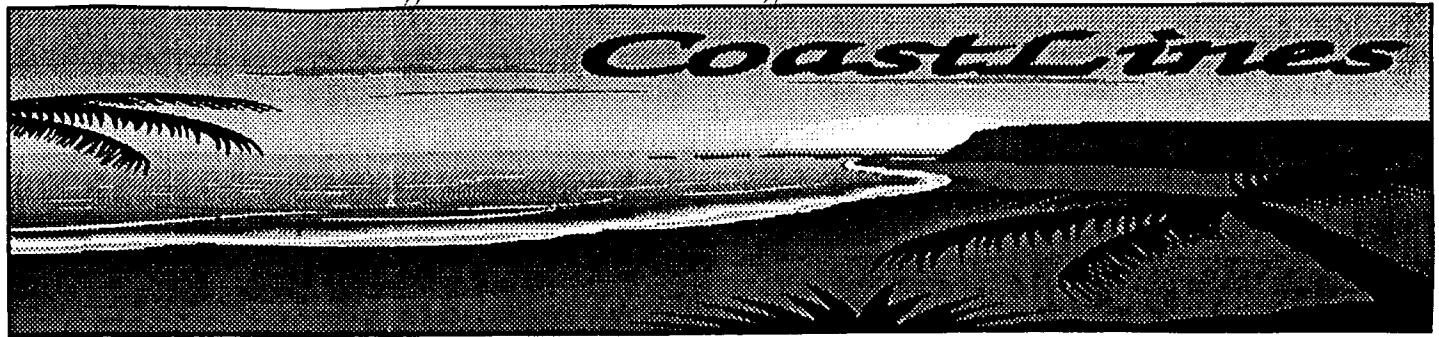

Two For One

By Jan Inouye

This year your membership card and name tag will serve double functions as we are combining them into one card. This 'new and improved' card will be laminated to add durability. Since you will always need this card with you to take advantage of your quilter's discount while shopping, you will also have it with you at the time of the guild meeting to use as your name tag. Clips will be available at every guild meeting to convert your membership card into your name tag. Your '2 for 1' card is attached to your 1998 roster. Thanks to all those early bird memberships plus the extra effort of Pat Yamada, the roster is available at the February guild meeting. Remember to keep your card at the end of the meeting instead of turning it in at the back table. This is yours to keep!!!

Get Ready For The Fair!

It's time again to start planning for this years faire! Entry forms are due April 11, 1998 from 9-5. Entries are due April 18 - 19 from 9-6pm.

There will be additional information in the March issue of Coast Line. For more information call Phyllis, 967-7140.

Welcome New Member!!!

By Jan Inouye

WELCOME NEW COASTAL QUILTERS GUILD MEMBERS!!! As we all know, quilter have a reputation for being the friendliest people on the earth, so remember to make an effort to talk to an unfamiliar face at least once during the break at every meeting. New members would love to get the inside scoop of all the 'quilter friendly' resources as well as understanding all the guild activities and terminology (i.e. fat quarters, block of the month, ect...) Even if you are a 'veteran' member, bet you still don't know EVERYONE. So start putting our other best talent to use (besides quilting)... talk and chat with each other.

Seanette Blaylock	569-4040	8/26
June Gerrard	961-9775	2/16
Leslie Hogan	968-7845	7/1
MaryAnn Huggins	646-3925	4/13
Kathy Iveland	964-5366	6/16
JoAnn Mailes	966-0969	7/21
Bonnie Orr	964-8231	2/8
Margie Rameriz	967-8806	5/24
Nancy Southard	969-0103	10/13
Eileen Tufenkian	685-8689	9/7
Jeanna ThunderHawk	964-6794	6/15
Nancy Velasquez	640-1430	12/21

January Door Prizes

By Joann Conklin

Your support of the door prize fund raiser in January was tremendous! Many thanks for your ticket purchases and donation of prizes. January's prizes were donated by:

MM Fabrics – Packet of Debbie Mumm squares.

Beverly Fabrics – Template materials and book “Weekend Basket Quilts”.

Heartwarmers Mercantile of Ojai – Bouquet of Fabrics.

The Fabric Well of Oxnard – Oriental fabrics.

Grant House – Quilter Rule Triangle.

Nancy's Notions - \$15 Gift certificate.

Sandy Hess – “The Quilt Encyclopedia Illustrated” book.

Bobbi Bocali – Quilt calendar.

Family of Mary Lou Williamson – “Wrapped in Glory” book.

Jane Manasse – The Quilt Engagement Calendar.

Kathy Pierce (Blue Island Quilts) – “Quilts, An American Legacy” book and 2 packets of fabric.

Look for some more great door prizes in February!!!

Birthdays

Feb 1	Judy Gorrindo
Feb 6	Lora Martin
Feb 7	Hilde Heller
Feb 8	Bonnie Orr
Feb 11	Joan Sutton
Feb 13	Jo Wamser
Feb 16	June Gerrard
	Colleen Ozab
	Marsha Williams
Feb 19	Mary Markow
Feb 20	Barbara Maxwell
Feb 24	Betty Kelley
	Liz Turner
Feb 26	Joan Buss
Feb 27	Oleta Bennett

Birthday's con't.

Feb 27	Anne Braddock Elisabeth Cooper Ruth Kyes
Feb 29	Madelyn Rowlands

Calendar of Events

Old Fans, New Fantasies. South Bay Quilters Guild, March 7 & 8, Torrence.

Village Quilters 2nd Annual Quilters Retreat. March 27-29, Camp Cedar Glen, Julian, Ca.

Quilt Show of Glendale. March 27-29. Burbank Hilton Convention Center.

World Quilt & Textile. Pasadena Center April 16-19.

El Camino Quilters 8th Annual Quilt Show. Rancho Buena Vista Adobe. April 24-26.

New Beginnings From Traditional Roots Tender Loving Care Quilters Guild. May 1&2. Covina Assembly of God Church.

14th Annual Craft Fair and Rib Burn Off. Sunset Park, Las Vegas, NV. May 2&3.

Spring Time in the Pines. Pine Tree Quilt Guild. May 2&3. Nevada County Fairgrounds, Grass Valley, CA.

Quilting in the Valley. Valley Quiltmakers Guild & San Fernando Valley Quilt Assoc. May 2&3. CSU Northridge, University Students Union.

Inland Empire Quilters Guild. May 16 & 17. All entries must be received by March 30.

Beach Cities Quilters Guild Quilt Show. May 30-31. Irvine Center.

Quilts Bring Friends Together. North Cities Quilt Guild. June 26 & 27. CSU Fullerton, Titan Student Union Building.

Camp Watcher-a-Patcher. Orange County Quilters Guild. Concordia University, Irvine.

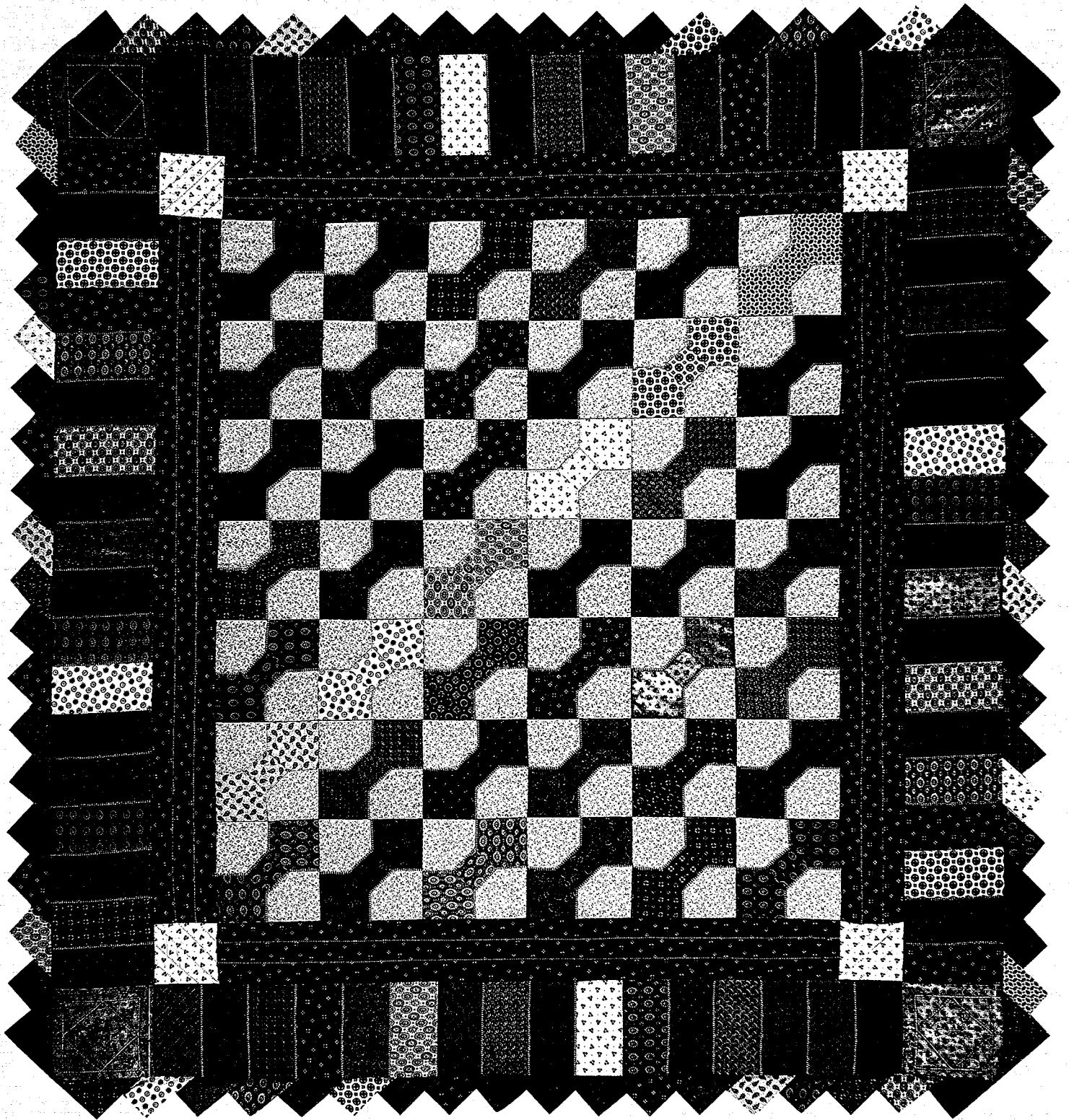

BOW TIE BEAUTY QUILT
Wall Quilt by **SHIRLEY BOTSFORD**

From her book, Daddy's Ties
VIP Fabrics 469 Seventh Avenue
New York, NY 10018 • 212-244-0794
www.cranstonvillage.com

BOW TIE BEAUTY Wall Quilt by SHIRLEY BOTSFORD ©1997 – From her book, Daddy's Ties

Fabric: 100% Cotton – 44”/45” wide – “My Father’s Ties” by  **V&P Fabrics**.

Pattern Level: Intermediate to Advanced.

Read through all the instructions before beginning.

1/4” seam allowances are used throughout and are included in the cutting measurements and templates.

Press all seams as you go.

Finished Size: 48” x 53” plus tie points.

Space does not permit including quilting basics. If you have questions, please visit the Cranston Village web site @ www.cranstonvillage.com and go to the Quilt Shop lessons. You may also write Shirley Botsford directly at Botsford Briar, PO Box 686, Beacon, NY 12508.

Materials Needed:

Note: This special quilt was made with over 42 “My Fathers Ties” prints. All of the prints in this collection are interchangeable so feel free to substitute available prints and adjust yardage accordingly.

“My Fathers Ties” – assorted print for Bow Ties, Strip-pieced Borders and Tie Points to equal 3 yards.

1 1/8 yard “Textures” pattern V0192-B (light blue) for base square

1/8 yard “My Fathers Ties” pattern V0101-E (yellow) for Inner Corners

1/2 yard “My Fathers Ties” pattern V0098-J (black) for Inner Borders

1/4 yard “My Fathers Ties” pattern V0101-R (red) for Outer Corners

3 yards of your choice for backing

Thin cotton batting-twin batt

Silver metallic thread for embellishing and quilting

Gray thread for construction

Template material - Oak tag or plastic

Cutting:

Template A (Bow Tie Section)- 42 pairs in assorted prints (84 total)

Template B (Knot Section) - One to match each pair in Template A (42 total)

Base Squares - Forty-two 5 1/2” x 5 1/2”

Inner Borders - Two 4 1/4” x 30 1/2”; Two 4 1/4” x 35 1/2”

Inner Corners - Four 4 1/4” x 4 1/4”

Outer Corners - Four 5 1/2” x 5 1/2”

Outer Borders Strips - Sixty-eight 3” x 5 1/2”

Tie Points - Seventy-six 2 3/4” x 5”

Note: Rotary cutting techniques may be used. It is best to complete the bow-tie center of the quilt and then, working outwards, make the borders to fit.

Assembly:

Note: Shirley’s own special “Stich and Flip” technique is used for the Bow Tie blocks. They look like patchwork blocks, but are actually a unique variation of appliqué. This eliminates the tricky inset corners associated with the Bow Tie patchwork pattern. If you prefer, the template can also be used for the traditional method.

1. Place under the seam allowance on the opposite sides of the Knot Section (B).
2. Using the window template, position B on the Base Square and pin.
3. Press under the seam allowances on the two short sides of the Bow Tie Section (A). Matching raw edges to the Knot, stitch and flip each side of the Bow Tie Section to the Knot on the Base Square.
4. Press, matching outer raw edges to the Base Square. Pin and use the Machine Blanket Stitch to finish both sides of the “appliqué”. (Hand stitches or other machine stitches also may be used.)
5. Make all the Bow Tie blocks and assemble them as shown.
6. Stitch the horizontal Inner Borders to the top and bottom of the joined Bow Tie blocks. Sew the corner blocks to the ends of the vertical inner border and attach them as shown.
7. Piece the Outer Borders and stitch them to the quilt top with Outer Corners as for the Inner Borders.
8. Fold each tie point piece in half crosswise. Match and stitch the raw edges together on one side. Turn right side out, center the seam and press flat.
9. Seam the backing together leaving an opening to turn at the center. Use the quilt top as a pattern to cut the backing and batting. Baste the batting to the back of the quilt top. Arrange and baste the Tie Points around the outer edge, matching the raw edges to the quilt, with points facing in, overlapping them as shown. Place 18 along top and bottom and 20 along each side.
10. With right sides together, stitch the backing around the outer edges of the quilt. Turn right side out through the opening in the backing. Slip stitch opening closed. Press lightly. Baste and quilt as desired.

SHIRLEY BOTSFORD'S BOW TIE

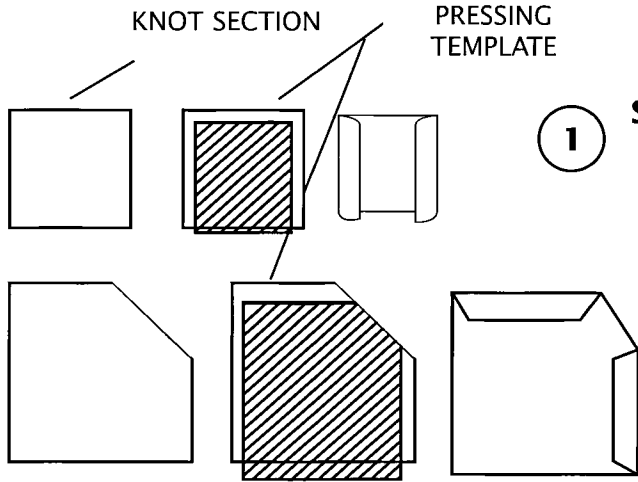

1 STEP ONE - PRESSING TEMPLATES

Artist Note:
 = CARDBOARD

2 STITCH AND FLIP USING WINDOW TEMPLATE

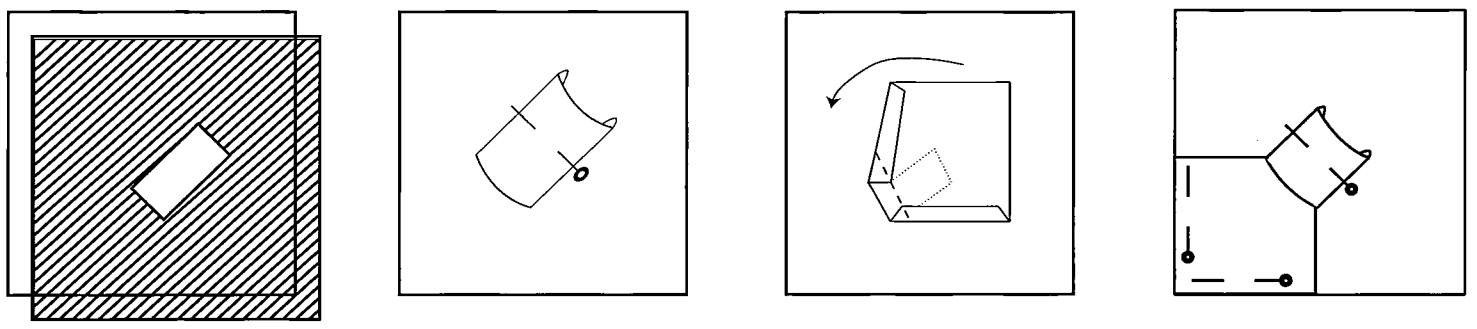

Step Two

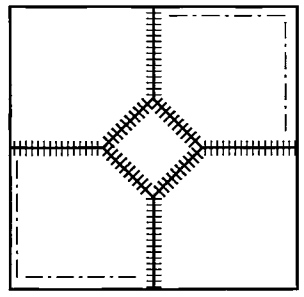

3 STEP THREE - HAND OR MACHINE FINISHING STITCHES

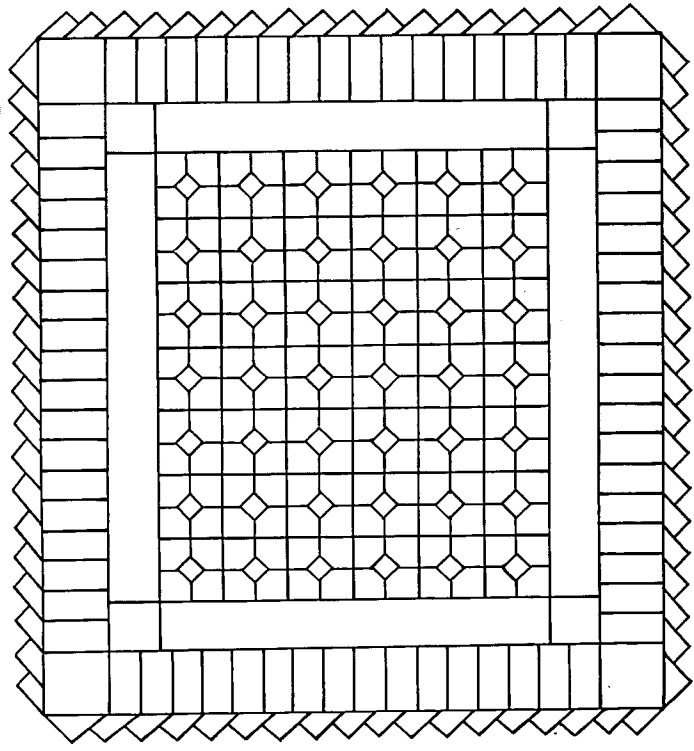

TEMPLATES – SHIRLEY BOTSFORD'S Bow Tie

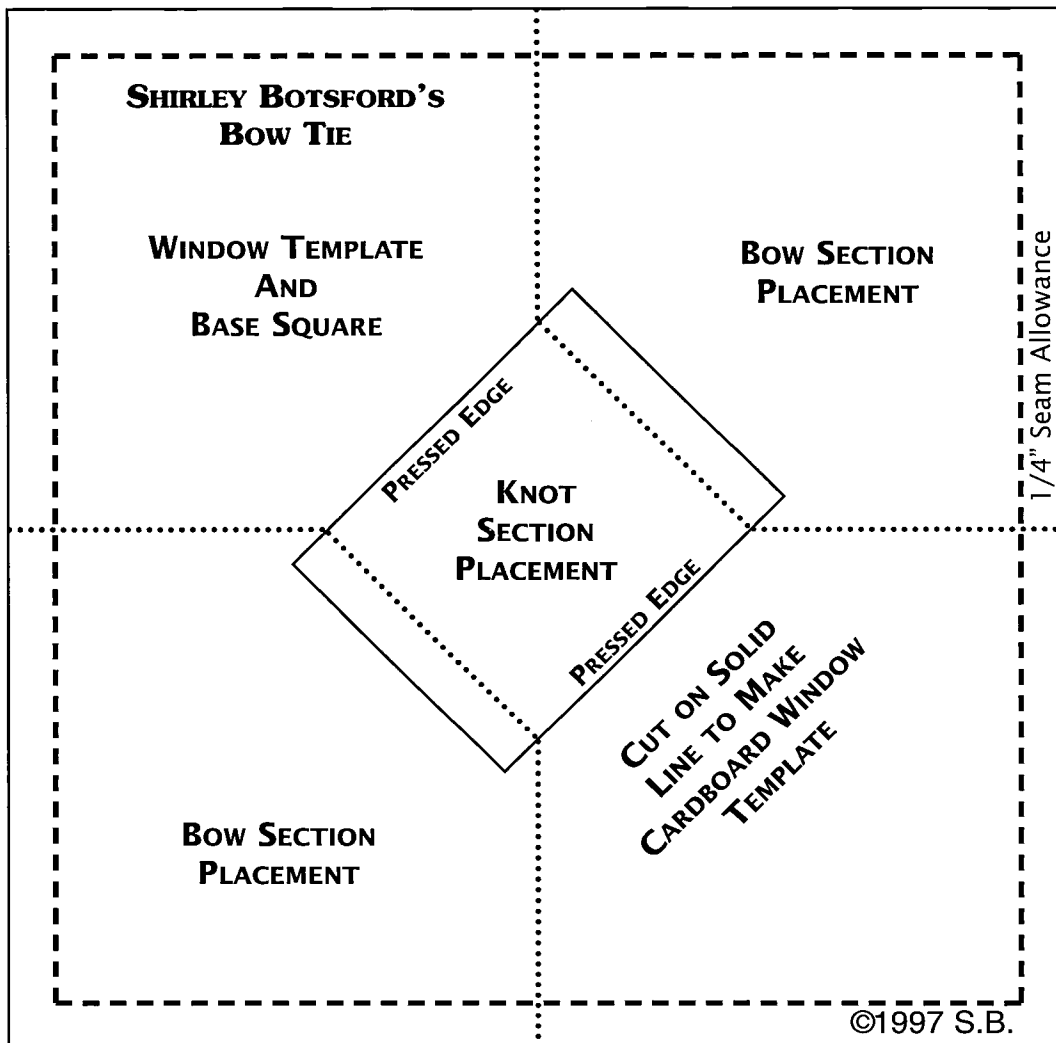
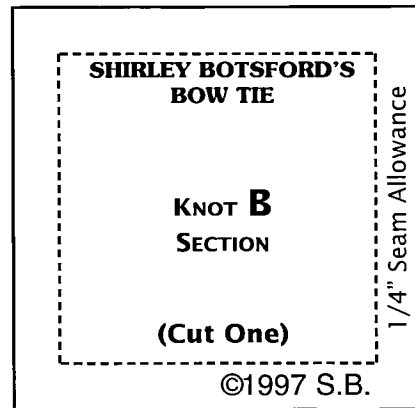
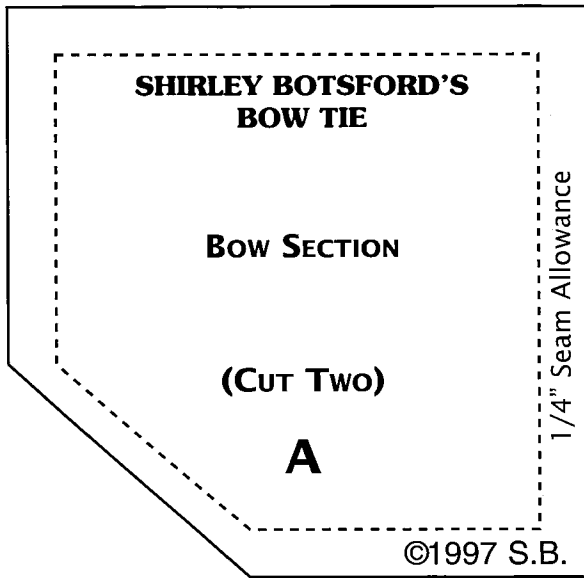

IRISH AMISH



How can an Amish be Irish? Easy! Just make a lovely Single Irish Chain in subtle shades of blue and lay it on a background of deep rich blacks.

This is a two block set. Cut a 10 1/2 inch square - and you have the first block.

The second block is made up of 2 1/2 inch squares. Cut 9 squares in plain blue. (Be sure to use a little variety in those blues. Cut 16 squares in black. (again, use a variety of blacks if you have them). Assemble them as below. It will also become a 10 1/2 inch block (both will finish at 10 inches)

BASICS: Use prewashed 100% cotton fabrics. Sew with 1/4 inch seams.

CAUTION: This chain becomes addictive!

Questions: Call Lena 682-3639 or Karin 569-7125

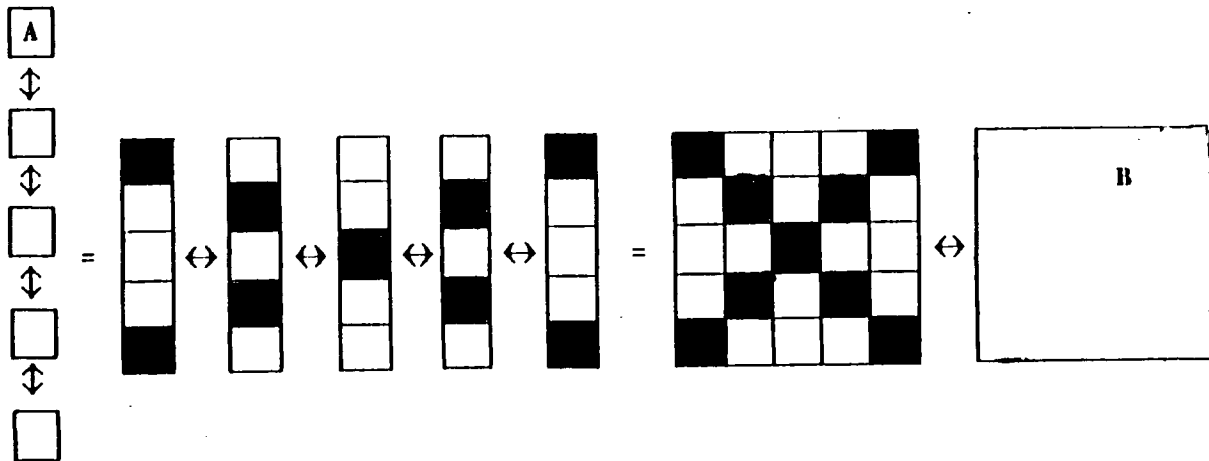

Coastal Quilter Guild

Web page address:

<http://www.west.net/nonprof/quilt>

Membership:

Guild meetings are held on the second Wednesday of each month at 7:00 p.m. at the Sanmarkand Community Center, 2550 Treasure Dr., Santa Barbara, CA. Please carpool, parking is limited. Coastal Quilters Guild of Santa Barbara and Goleta is a non profit, educational and charitable organization. It is the purpose of the Guild to educate it's members about the history and preservation of the art form of quilt making and its related topics. Also to learn new techniques, improve skills and to inform the community at large about our quilt making heritage.

New Members and Membership Renewals:

Mail your membership form, check or Money Order for \$25 payable to:

Coastal Quilters Guild, Inc
P.O.Box 6341
Santa Barbara, CA 93160
Attn: Membership

Coast Lines Newsletter:

Coast Lines is a monthly publication. The deadline for newsletter articles is the last Wednesday of the month for the following issue. Send articles to my home: Jeanna ThunderHawk

5400 Hollister Ave
Santa Barbara, CA 93111
Attn: Newsletter



Coastal Quilters
of Santa Barbara & Goleta, Inc.
P.O. Box 6341
Santa Barbara, CA 93160

